

DENSO

Member of the TOYOTA Group

Superior ID-Technology



Bar Code Handy Terminal



BHT-300 Series

The New Standard in BHT Scanners

BHT-300 Series: robust, flexible and with numerous features.

Whether you use wireless LAN, Bluetooth™, infrared or radio frequency for data transfer, Denso's new BHT-300 series is ideal for fast and simple inventory and stocktaking. Nor does it matter if you work with one or two-dimensional barcodes – the BHT-300 series has the right device for all your requirements.

Reading

High reading performance

- Scanning at ranges up to 450 mm (with narrow 1.2 mm bar width)
- Improved scanning of broader labels and badly printed or damaged bar codes

Viewing

Largest screen in its class

- Choose between a large, easy-to-read font size or a display of up to 9 lines with 22 characters each (12 point font)
- Alphanumeric characters, Kana and Kanji
- Compatibility mode with an 8-character, 4-line display for applications from earlier models (BHT-7000/-5000/-8000)
- The characters can be enlarged horizontally, vertically and simultaneously horizontally/vertically



Communication

Built-in wireless communication interface for connection to an existing LAN

- The BHT-300BW/BWB models are compatible with the global standard IEEE802.11b enabling wireless communication with up to 11 Mbps
- The BHT-300BB/BWB models are fitted with Bluetooth™ – enabling wireless connection to portable printers

Performance and Quality

- Industry-leading impact resistance and superior operating environment features (the BHT-300 withstands being dropped onto concrete from a height of 1.20 m 30 times)
- Water and dust-resistance meet the IEC requirements of the International Standards Protection Class IP 54 (equivalent to JIS splash proof)
- Power-saving design achieves longer operating time
- A lithium-ion battery and power-saving design extends continuous operating time and reduces costs by eliminating the need for replacement batteries as well as the inconvenience of managing battery recharging: 135 hours when reading two bar codes twice in 10 seconds and not using the wireless interface. 24 hours assuming a reading to wireless communication to display to standby mode ratio of 1:1:1:20 (BHT-300BW/BWB)
- CCD (Charged Coupled Device) technology: No moving parts, very robust

Extended scope of function

User-friendly Design

The angled scanner head and lightweight body improve user productivity – ideal for retail, logistics and warehousing applications.

Easy-to-use, highly durable key pad

Magic keys to which you can assign any

Technical Data

Memory			5 MB	
Display	Resolution			
	Display device			
	Character type	Alphanumeric Kana		
Kanji characters (standard)				
Kanji characters (standard)				
Scanner	Scanning system			
	Scanning area			
	Readable Codes			
	Resolution			
	Reading confirmation			
Keyboard	Number of keys			
Communications	Optical Interface	Communication system		
		Communication speed		
		Max. distance		
	Wireless Interface	Certificate		
		Frequency		
		Range ⁽¹⁾		
		Modulation		
		Communication speed		
		Cable interface		
	Power supply	Main power		
Operating hours				
Backup power				
Auxiliary functions				
Environmental Requirements	Operating temperature			
	Water/dust proof			
	Shock resistant		1,50	
Weight			Appr	

(1): Maximum range and speed may vary according to operating condition

(2): when reading two bar codes at 10-second intervals and not using the

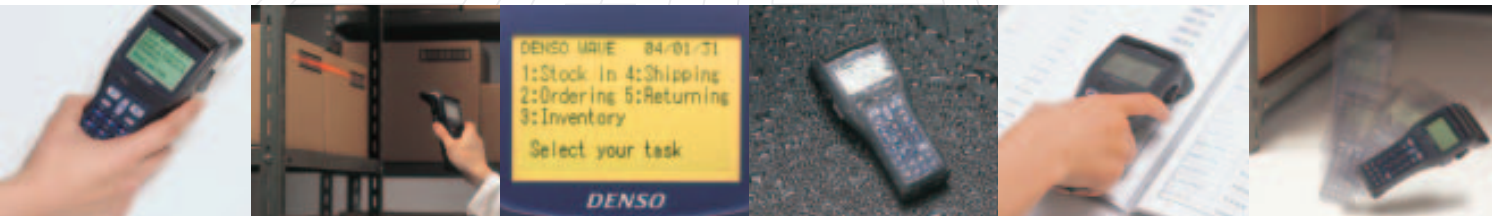

functions you wish. Cursor key enhances menu selection convenience.

Resin-coated keys enhance durability.

Extension Pack

The BHT-300 series is compatible with BHT-BASIC 4.0, which is now equipped with easy to use functions – it is compatible with earlier models and enables uncomplicated transfer of applications.

Vibrator

The vibrator reliably informs the user when the reading process has been completed and if any errors have occurred – even in noisy working environments.

Remote Wakeup Function

Makes it possible for it to be controlled from a PC and enables remote maintenance of master files, applications and operating systems.

BHT Extension Pack

BHT pack for creating applications

High performance development software for the whole process, from development to implementation. Easy installation, can be implemented immediately.

BHT-302B	BHT-303B	BHT-303BB	BHT-303BW (303BWB)	BHT-304Q	BHT-304QW
3 MB (User area approx.: 2.2 MB)	9 MB (User area approx.: 5.8 MB)	9 MB	9 MB (User area approx.: 5.25 MB)	18 MB (User area approx.: 12.5 MB)	18 MB (User area approx.: 12 MB)
132 x 72 dots					
Liquid crystal dot matrix display (Monochrome)					
9 cha. zu 22 lines					
4 cha. zu 8 lines					
6 cha. x 11 lines					
Advanced Scanning (CCD) 1D					Advanced Scanning (CCD) 2D
420 mm max (with a distance of 400 mm from label)					
EAN-13/-8 (JAN-13/-8), UPC-A/-E, UPC/EAN with add-on codes, Interleaved 2 of 5, CODABAR (NW-7), CODE39, CODE93, CODE128 (EAN-128), Standard 2 of 5					
1.25 mm					
2-color LED (red & green), buzzer, vibrator					
26 keys (Incl. power switch) + 2 trigger keys					
Infrared interface (IrDA-SIR Ver. 1.2[Low Power] compliant)					
Approx. 115.2 Kbps max					
Approx. 15 cm					
Bluetooth™		IEEE802.11b (Bluetooth™)		IEEE802.11b	
		2.4 GHz		2.4 GHz	
		Indoors: approx. 75 m Outdoors: approx. 200 m		Indoors: approx. 75 m Outdoors: approx. 200 m	
		DSSS		DSSS	
		11/5.5/2.1 Mbps (with auto fallback)		11/5.5/2.1 Mbps (with auto fallback)	
		RS-232C (115,2 Kbps max)		RS-232C (115.2 Kbps max)	
Lithium ion battery cartridge					
Approx. 135 hours ⁽³⁾			Approx. 24 hours ⁽³⁾		
Clock, beeper, vibrator, low battery indication, remote wakeup functions					
-5 °C ~ 50 °C					
IP 54 (IS splash Proof)					
1,20 m (30 times onto concrete floor)			1,20 m (30 times onto concrete floor) ⁽⁴⁾		
Approx. 230 g		Approx. 240 g	Approx. 250 g (260 g)	Approx. 260 g	

... wireless interface.

(3): Reserve power calculation assuming a reading to wireless communication to display to standby mode ration of 1:1:1:20.
(4): Test value, not guaranteed.

Bluetooth is the registered trademark of Bluetooth SIG Inc. and is used under licence by Denso Wave.

Note

Carefully read the user manual before using the device. Specifications are subject to change without notice. Information current as of June 2004.

Accessories

- Hand strap
- Lithium-ion Battery BT-20L
- Operating Manual

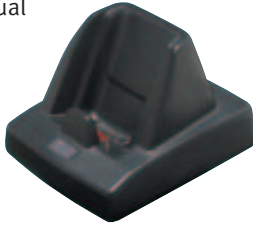

Optional Accessories (not supplied)

- Communication units:
CU-301 (RS-232C)
CU-321 (USB)
CU-311 (LAN) (available shortly)
- Battery charger for the main power supply battery (CH-351)
- Soft case and belt case (available shortly)

Dimensions (in mm)

BHT-300 Series

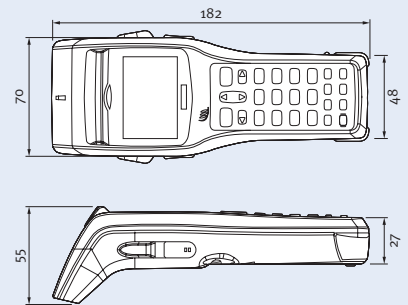

CU-300 Series

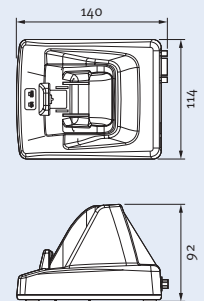

Technical Data CU 300

			CU-301	CU-321 ⁽¹⁾
Communication	BHT ← → CU (Communication unit)	Communication system	IrDA-SIR Ver. 1.2 (Low Power) compliant	
		Communication speed	115.2 Kbps MAX	
	CU ← → Host	Communication system	RS-232C	USB 1.1 Full Speed compliant
Display	LEDs		Power, communication	
Battery charger	Charge time		4 hours	9 hours ⁽²⁾
Power source			AC/DC adapter	From connected device

(1): Connection may not be possible depending on the type of PC or USB hub being used. First check if they are compatible. The AC/DC adapter (not included in the scope of delivery) is required for recharging or discharging the battery if no power supply is available via the connected device, such as when this is switched off or is in standby mode.

(2): Charge time may vary according to the power supplied by the connected device. Charge time with the AC/DC adapter is 4 hours.

Company Stamp